



## DIN 6499 (ISO 15488) System ER

Collet chucks for collets DIN 6499 (ISO 15488) ER-system  
Mandrins à pinces pour pinces DIN 6499 (ISO 15488) système ER



**Verwendung:**  
Zur Aufnahme von Werkzeugen mit Zylinderschaft in Spannzangen.  
**Application:**  
For mounting straight-shank tools in collets.  
**Application:**  
Pour le serrage d'outils avec queue cylindrique dans des pinces de serrage.

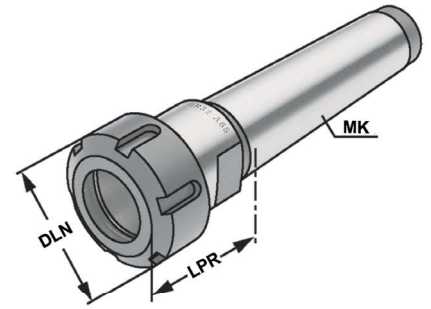

Bestell-Nr. Order no. Référence	MK MT CM	THSZMS	DCONWS Spannbereich Capacity   Capacité	Typ	LPR	DLN	DRVS
108.02.01	MK 2	M10	1 – 10	426E   ER 16	45	32	18
108.02.011	MK 2	M10	2 – 16	430E   ER 25	50	42	18
108.02.012	MK 2	M10	2 – 20	470E   ER 32	70	50	18
108.02.02	MK 3	M12	2 – 16	430E   ER 25	56	42	24
108.02.03	MK 3	M12	2 – 20	470E   ER 32	70	50	24
108.02.04	MK 4	M16	2 – 16	430E   ER 25	63	42	32
108.02.05	MK 4	M16	2 – 20	470E   ER 32	65	50	32
108.02.06	MK 5	M20	3 – 26	472E   ER 40	86	63	45

**Lieferumfang:** Mit gewuchteter Spannmutter  
**Delivery:** With balanced clamping nut  
**Livraison:** Avec écrou de serrage équilibré

